

L形擁壁

構造図

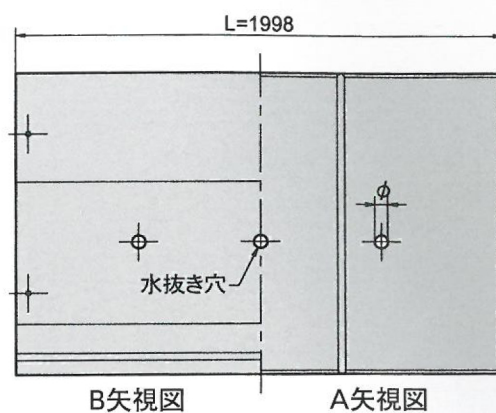
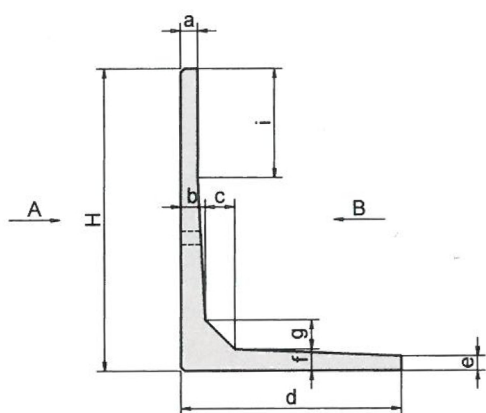
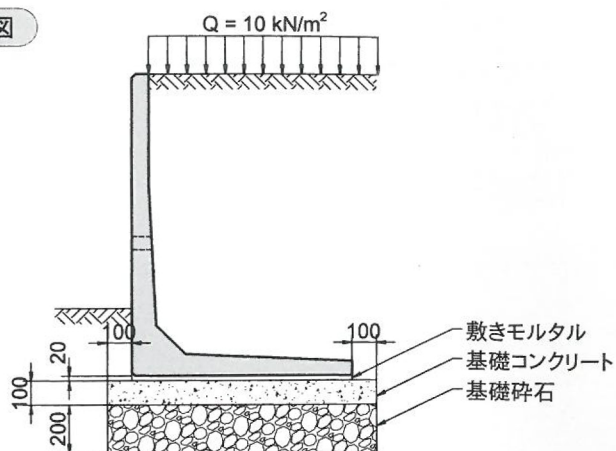

呼び	寸法 mm									水抜き穴		質量 kg	必要地耐力 kN/m ²
	a	b	c	d	e	f	g	H	i	φ	数		
500	70	70	100	400	60	60	100	500	—	55	1	281	31
600	70	70	100	500	60	60	100	600	—	55	1	342	33
700	70	70	100	550	60	60	100	700	—	55	1	389	38
800	70	70	100	600	60	60	100	800	—	55	1	436	43
900	70	70	100	650	60	60	100	900	—	55	2	483	47
1000	70	70	100	700	60	60	100	1000	—	55	2	530	52
1100	70	70	100	800	60	70	100	1100	—	55	2	610	53
1200	70	70	100	850	60	70	100	1200	—	55	2	658	57
1250	70	80	120	900	60	80	120	1250	450	55	2	743	58
1300	70	80	120	900	60	80	120	1300	500	55	2	760	62
1400	70	90	120	950	60	90	120	1400	500	55	2	857	67
1500	70	100	120	1000	60	100	120	1500	500	55	2	962	72
1600	70	100	120	1100	60	100	120	1600	500	55	3	1040	72
1750	80	110	140	1200	70	110	140	1750	450	55	3	1290	77
1800	80	110	140	1200	70	110	140	1800	500	55	3	1310	81
2000	80	130	150	1300	70	130	150	2000	500	55	3	1580	90
2250	100	140	150	1450	80	140	150	2250	1000	75	2	1950	98
2500	100	150	150	1600	80	150	150	2500	1000	75	2	2250	106
2750	100	180	200	1750	80	180	200	2750	1000	75	2	2790	116
3000	100	200	200	1900	80	200	200	3000	1000	75	2	3240	125
3500	130	260	200	2250	150	260	300	3500	1500	75	3	5030	142
4000	130	280	200	2500	150	280	300	4000	1500	75	3	5970	161